

Technical data sheet for

BENCH TOPS 450mm

BT8450-CB, BT8450-LS



BT8450-CB

- Heavy-duty construction
- Cabinet Base or Leg Stand
- Stainless steel exterior
- Easy clean
- Fully modular

Series Options

- BT** - Standard splashback models
- BTL** - Low back models
- BTB** - Bold vitreous enamel colour front finish on standard splashback models
- BTLB** - Bold vitreous enamel colour front finish on low back models

Overall Construction

WORK BENCH

- 3.5mm thick compound work surface
 - 1.5mm 304 stainless steel top
 - 2.0mm galvanised steel backing
- Welded 1.5mm stainless steel bull nose
- Splashback and side panels 1.2mm stainless steel

CABINET BASE (SUPPLIED AS -CB MODEL)

- Modular for suite matched finish
- Double skin 0.9mm stainless steel interior and exterior
- GN 1/14 position racking kit
- 63mm dia. heavy-duty 1.2mm stainless steel legs with adjustable feet

LEG STAND (SUPPLIED AS -LS MODEL)

- Modular for suite matched finish
 - 63mm dia. heavy-duty 1.2mm stainless steel legs with adjustable feet
 - Framed stand shelf with 0.9mm stainless steel finish
 - Quick assembly design (no tools required)
-

Technical data sheet for BENCH TOPS 450mm

Specifications

DIMENSIONS

All models
Width 450mm
Depth 805mm
Height 915mm
Incl. splashback 1130mm
Incl. low back 972mm

NETT WEIGHT

Cabinet Base models
52kg

Leg Stand models
40kg

PACKING DATA

Cabinet Base models
0.55m³, 93kg
Width 495mm
Depth 870mm
Height 1260mm

Leg Stand models
0.29m³, 74kg
Width 495mm
Depth 870mm
Height 665mm

OPTIONS AT EXTRA COST

Castors
Plinth mounting

BT8450-CB, BTL8450-CB

CABINET BASE

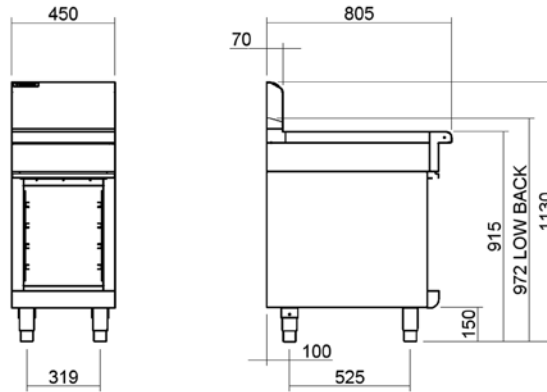

BT8450-LS, BTL8450-LS

LEG STAND

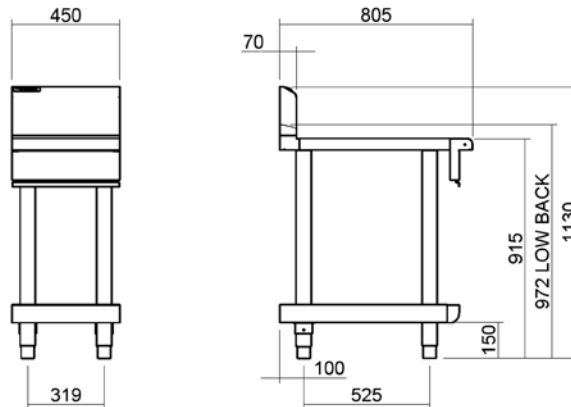

BT8450

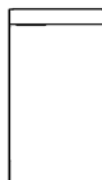

moffat.com.au
moffat.co.nz

Australia
moffat.com.au

Moffat Pty Limited

Victoria/Tasmania
740 Springvale Road
Mulgrave, Victoria 3170
Telephone +613-9518 3888
Facsimile +613-9518 3833
vsales@moffat.com.au

New South Wales
Telephone +612-8833 4111
nswsales@moffat.com.au

South Australia
Telephone +613-9518 3888
vsales@moffat.com.au

Queensland
Telephone +617-3630 8600
qldsales@moffat.com.au

Western Australia
Telephone +618-9413 2400
wasaes@moffat.com.au

New Zealand
moffat.co.nz

Moffat Limited

Rolleston
45 Illinois Drive
Izone Business Hub
Rolleston 7675
Telephone +64 3-983 6600
Facsimile +64 3-983 6660
sales@moffat.co.nz

Auckland
Telephone +64 9-574 3150
sales@moffat.co.nz



ISO9001
Quality
Management
Standard

In line with policy to continually develop and improve its products, Moffat Limited reserves the right to change specifications and design without notice.

© Copyright Moffat Ltd
AN.W8.08/19