

PRESSURE FRYER 25L FLOOR STANDING MICROCOMPUTER CONTROL

MANUFACTURING
SINCE 1966



Model: PFE0800



FEATURES

- Built-in filtration system reduces downtime and increases employees' productivity.
- 10 programmable cook cycle.
- Can program 10 different temperature, solenoid valve function for different cooking stage.
- Programmable control, LED time/temp display and simple up/down arrows.
- Heavy-duty stainless steel rectangular fry pot for easy-cleaning and long life.
- Larger 6-head capacity fry pot
- High-efficiency heating elements generate fast temperature recovery and energy savings
- Cast aluminum alloy lid is strong but light for easy handling.
- Color-keyed locking spindle engages pressure seal.
- Lid-lock system keeps lid locked until pressure reaches 1 psi.
- Raised edge on deck reduces spills
- Channel under lid helps direct condensation away from pot when lid is open
- High-limit temperature protection
- 4 heavy duty casters, 2 locking.

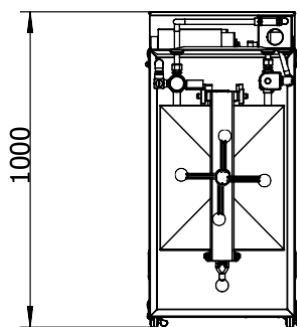
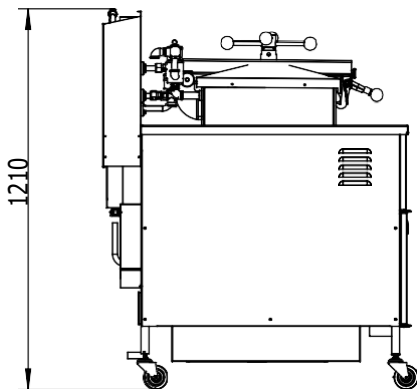
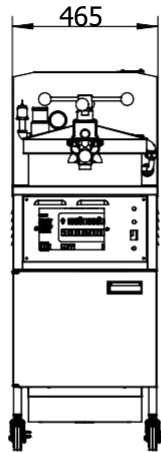
Model: PFE0800

SPECIFICATIONS

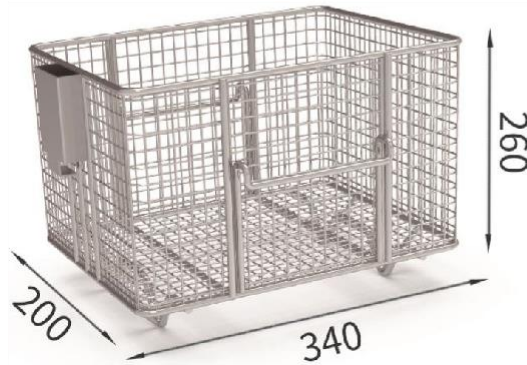
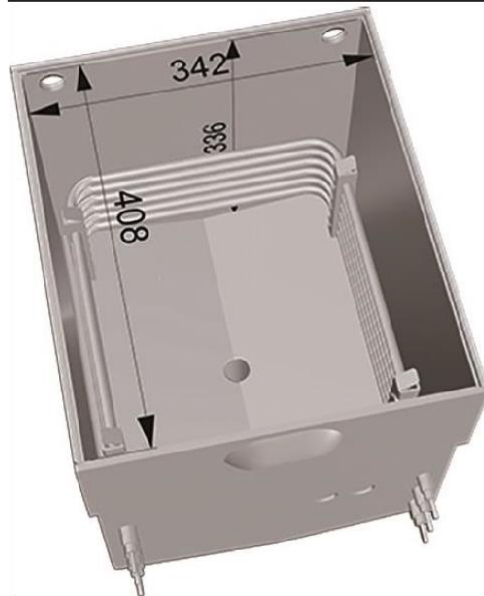
POWER	13.5kW
VOLTAGE	400V ~50Hz 3Phase
PACKAGING (W x D x H)	560 x 1225 x 1300mm
UNIT (W x D x H)	486 x 1000 x 1220mm
NET WEIGHT	130kg
GROSS WEIGHT	150kg
TEMP. RANGE	Ambient-200°C
VOLUME OF OIL	25Lt
WORKING PRESSURE	0.085MPa
PRODUCT OUTPUT	Approx 25kg

BASKET

OIL TANK

NOTE

- When viewing the appliance from the front in it's usual operating position, the width (W) of the product is the total distance from left to right; the depth (D) of the product is the total distance from the front to the back; the height (H) is the total distance from the bottom of the product to the top. Pictures may vary from actual product.